



Screw compressors

SCR-PM2

power range 7,5-11-15 kW

SCR - innovative and quality compressors



For more than 20 years, the SCR brand has been one of the world's leading screw compressor manufacturers thanks to its in-house development and design, the use of advanced technologies and, above all, unique design solutions that are appreciated by customers worldwide who are looking for machines with a modern concept and high energy efficiency.

Since 2018, SCR has been part of the Japanese concern ANEST IWATA, which brings to the SCR screw compressor portfolio the traditional Japanese emphasis on production organization, a strict management system and quality assurance. The result of the synthesis of the concepts of both companies is top-designed machines with unique benefits and uncompromising reliability.

The revolutionary SCR-PM2 compressor is here!

The SCR-PM2 compressor series is an exceptional design that pushes the boundaries in compressed air efficiency and user-friendliness. Using robust screw blocks, 1:1 lossless drive, IE4 permanent magnet motors and variable speed control by frequency converter, the SCR-PM2 offers extreme efficiency and increased savings potential in compressed air production. All this is combined with unique design features such as a patented oil separation solution or a hinged cover for maximum comfort during machine maintenance. The result is a unique compressor with high efficiency and perfect compactness.

MAJOR BENEFITS

- ✓ maximum energy saving
- ✓ robust air end with low speed
- ✓ lossless direct drive 1:1
- ✓ electric motor IE4 with permanent magnets
- ✓ speed control by frequency converter
- ✓ electronic controller
- ✓ unique oil separation system
- ✓ compact machine with minimal dimensions
- ✓ perfect approach to maintenance
- ✓ 5-year extended warranty option



How much does it cost to produce air?

Compressed air is one of the most expensive forms of energy used in craft workshops and manufacturing companies. In the long term, the cost of air production has 4 main components, with the cost of electricity used to run the compressor clearly outweighing the other components.

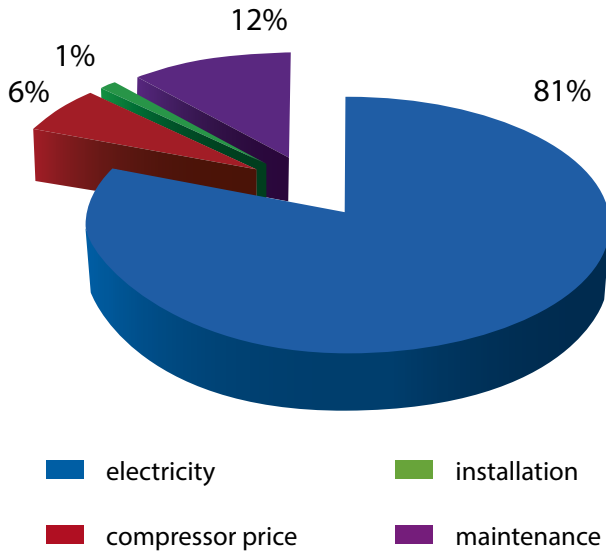

Cost over 10 years of operation

The normal lifetime of a compressor is at least 10 years. During this time, typically over 80% of all costs associated with compressed air are electricity costs. Simply put, you pay more than 13 times more for electricity than for the entire machine. So it certainly doesn't pay to buy a cheap but energy-inefficient compressor.

What is the amount?

Even with smaller screw compressors, it is definitely worth looking not only at the price of the machine, but also at its energy efficiency. The energy costs incurred over the expected lifetime of the machine of 10 to 15 years are many times higher than the initial investment.

Usual annual energy costs *

	7.5 kW	11 kW	15 kW
1000 MH	1 800 €	2 700 €	3 400 €
2000 MH	3 600 €	5 400 €	6 700 €
4000 MH	7 200 €	10 700 €	13 400 €

* The amounts are given for a model calculation of a fixed-speed V-belt compressor with 10 bar pressure, 270 litre vessel, 1.5 bar switching differential and 30 sec run time. Considered electricity price 0,16 €/kWh.



Annual cost for the power input of 11 kW in single-shift operation

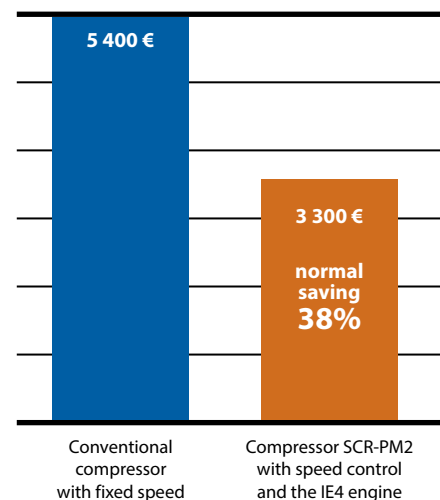

SCR-PM2 compressors can reduce energy costs in an extreme way. Savings are typically as high as 38%, but in some cases as high as 50%. The basis for this reduction is the elimination of idling due to the infinitely variable speed control, the lossless 1:1 gearing, the high efficiency of the screw block and the use of state-of-the-art IE4 permanent magnet motors.

Design arrangement



Lossless direct drive 1:1

Thanks to the direct connection of the screw block to the electric motor, the SCR-PM2 series compressors operate without any energy loss in the transmission system. Compared to compressors with V-belts, coupling or gearbox, this eliminates any maintenance and, in addition to energy savings, the user also saves on machine maintenance.



Quality airend

- ✓ ALLY WIN technology developed in Germany
- ✓ low speed up to 2800 rpm
- ✓ robust dimensions
- ✓ long service life
- ✓ high air compression efficiency

5% saving
of energy

PM motor with IE4 efficiency

The SCR-PM2 series brings the latest in oil-lubricated permanent magnet motor technology to the world of small screw compressors. The used PM motors, due to their design, have an extreme efficiency that exceeds the IE4 efficiency requirements of IEC EN 60034 and exceeds the conventional IE2 efficiency motors used as a standard solution for variable speed compressors by an average of 5%.

- ✓ high efficiency IE4
- ✓ compact dimensions
- ✓ without bearings
- ✓ oil cooling
- ✓ electrical protection IP65 - dust proof
- ✓ PTC temperature protection

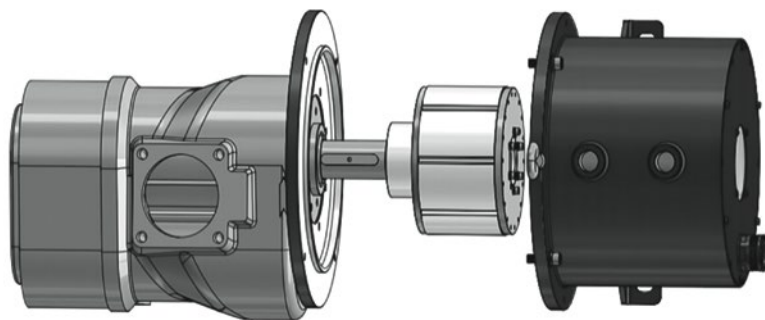

Power kW	SCR-PM2 main motor	Efficiency IE4	Efficiency IE3	Efficiency IE2
7.5	93.0%	91.7%	90.1%	88.1%
11	93.5%	92.6%	91.2%	89.4%
15	93.5%	93.3%	91.9%	90.3%

Speed control by frequency converter

Traditional fixed-speed compressors are controlled in duty cycles, where the compressor alternates between running under load, idling or stopped. Immediately after start-up, air compression is initiated and the main engine is under load. When the required pressure is reached, the compressor switches to idle mode, where the compressor does not produce air, but the motor is still idling the air end and needs power. Idling on one side makes it easier to start the machine again, but for a few tens of seconds, unnecessary energy consumption occurs, which usually reaches tens of percent of the total energy consumed. The lower the air consumption, the more the idle ratio increases, opening up the possibility of achieving significant savings on the cost of the produced air and the operating costs associated with the compressor.

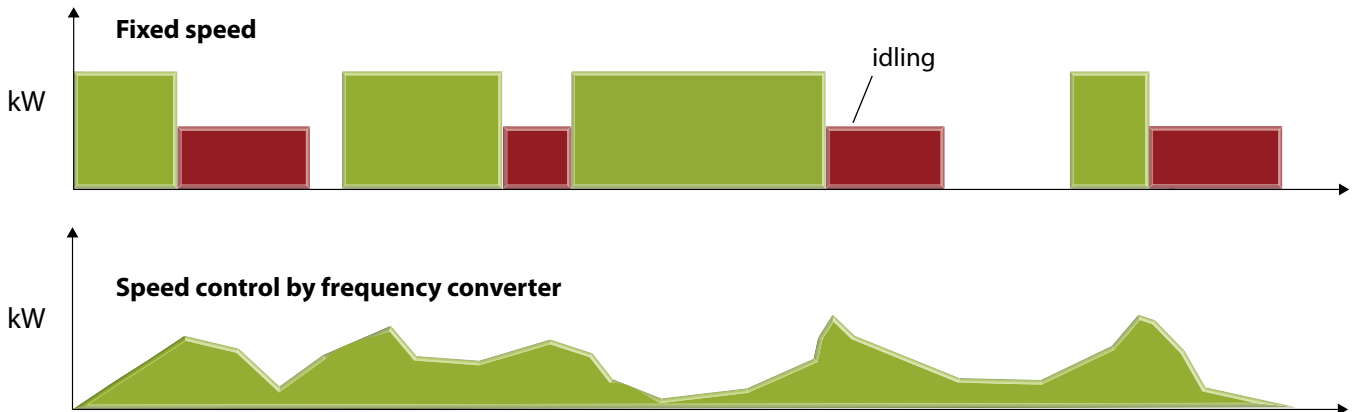

Continuous speed control

The SCR-PM2 compressors are equipped with state-of-the-art INOVANCE CP 700 SCR frequency converters, which allow them to maintain the required output pressure and adapt the speed of the drive unit to the immediate needs of the compressed air supply. Thanks to this modern compressor control system, idling is significantly eliminated and energy savings of tens of percent are achieved. Further cost reductions can easily be achieved by quickly changing the output pressure setting and the control pressure band.



Typical energy savings as a function of air consumption versus maximum compressor output (FAD)

Air consumption	kW	50%	60%	70%	80%	90%	100%
Compressor FS at 10 bar × SCR-PM2 at 10 bar	7.5	20.4%	16.5%	12.3%	9.1%	4.1%	0.5%
	11	28.2%	24.4%	20.1%	14.5%	7.5%	3.6%
	15	35.5%	31.7%	26.7%	21.7%	15.8%	8.1%
Compressor FS at 10 bar × SCR-PM2 at 7 bar	7.5	45.3%	42.9%	39.6%	37.1%	33.9%	30.4%
	11	50.1%	51.3%	41.5%	37.2%	34.1%	28.8%
	15	49.6%	46.6%	43.1%	39.2%	34.6%	28.5%

FS (fixed speed) = conventional fixed speed compressor with V-belt drive.

Modern electronic controller

The SCR-PM2 series compressors are controlled by the modern iPanel SOP-20 electronic controller with simple push-button operation, monochrome line display and many useful functions for machine operators and service organizations.

SOP-20 unit options

- ✓ precise adjustment of the output pressure
- ✓ current machine status values
- ✓ setting of operating parameters
- ✓ weekly plan for cost reduction
- ✓ alarms and service alerts
- ✓ history of errors
- ✓ automatic restart after power failure
- ✓ user-friendly operation

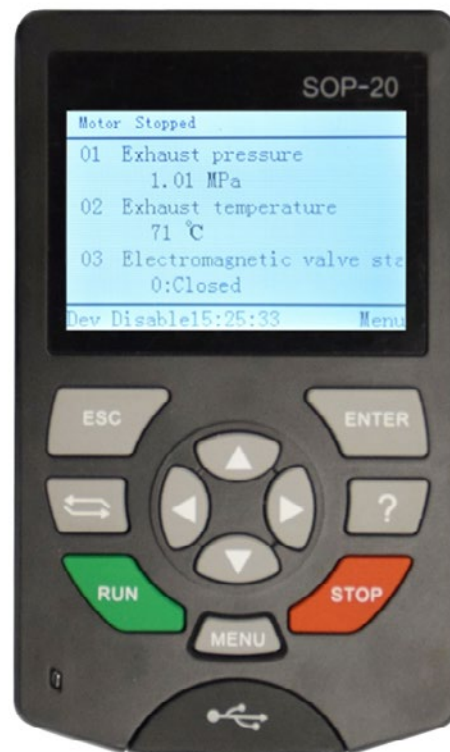

Practical benefits for fast service

One unit for compressor and frequency converter

The SOP-20 control panel allows the compressor and frequency converter parameters to be set together in one environment instead of separate units with completely different controls.

Easy exchange

The SOP-20 unit can be very easily flipped out, disconnected from the regular RJ45 UTP connector and replaced; no laborious disconnection of electrical wires from connection terminals and ports is required.

Easy connection to a computer

Connection to a computer is made using a standard USB Mini cable; once connected, the drive loads similarly to a mobile phone or camera and no special software installation is required.

Memory card

All operating parameters and control programs with parameter settings are stored on a standard SD Micro memory card.

Unique pressure vessel

The innovative concept of the double chamber pressure vessel integrates a receiver for the accumulation of produced compressed air together with a unique oil separation system in the oil section equipped with a labyrinth structure for effective reduction of the oil content in the outlet air. The combination of the two vessels into one unit allows, in particular, a radical reduction in the size of the machine and increases its compactness during installation.

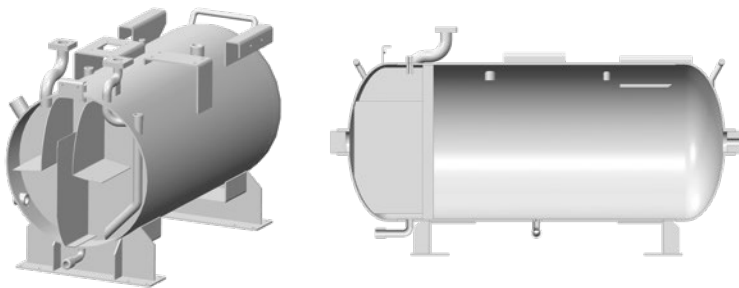

- ✓ unique patented solution
- ✓ air received part with 128 l volume
- ✓ air quality with oil content < 3 ppm
- ✓ comfortable condensate and oil drainage
- ✓ possibility of attaching wheels

Comfort down to the last detail

The SCR-PM2 compressors are equipped with many small details to make life easier for the machine operator. Our priority is not to sacrifice machine equipment at the expense of the final price and to find new ways to make SCR machines more customer-friendly.



- ✓ **glycerine pressure gauges** - instantaneous reading of the pressure in the receiver and oil reservoir
- ✓ **practical oil refilling** - unique small door makes it easy to change and refill the oil
- ✓ **oil gauge on the outside** - no need to remove the panels to check the oil level
- ✓ **pipes instead of hoses** - no more leaking oil and burst rubber hoses
- ✓ **ball valve** - pre-assembled fittings for immediate connection to the pipe

Quality original parts & affordable service

To ensure that the compressor achieves continuous peak performance and to minimise the risk of failure throughout the lifetime of the machine, the compressor must be maintained at prescribed intervals and only with genuine spare parts and lubricants.

All necessary spare parts are available for each SCR-PM2 compressor and can be easily selected according to the documentation provided or by their marking directly on the part inside the machine.

SCR-PM2 compressors are maintained and serviced by an extensive network of service partners to ensure that all necessary services are readily and quickly available without unnecessary technician call-out costs.



Incredible maintenance comfort

You won't find a compressor on the market with more convenient access for machine maintenance or servicing. While with most compressors you often have to remove several panels to access the parts, with the SCR-PM2 compressor series you only need to unscrew a single screw and by removing the cover you have immediate access to all the parts. Thanks to the hinged cover, compressor downtime for routine inspections and periodic maintenance is minimised.

Thanks to the advanced design concept, compressor maintenance is eliminated to only a few basic tasks. Long-term machine maintenance costs are thus significantly reduced to an absolute minimum.

CHEAPER MAINTENANCE

- ✓ eliminates replacements and tensioning of V-belts
- ✓ without cracked and leaking hoses
- ✓ no motor bearing replacements
- ✓ without coupling or gearbox maintenance
- ✓ speeding up the work of technicians

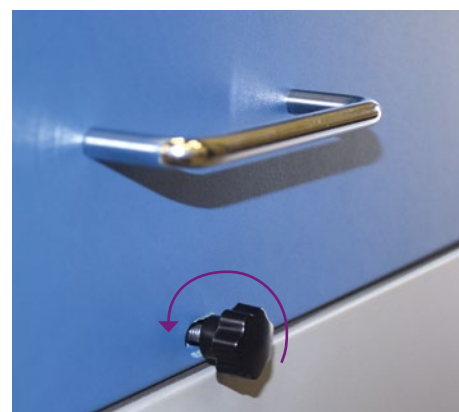

Technical data

Order No.	Power (kW)	Pressure (bar)	FAD performance (l/min)	Receiver (l)	Thread (")	Ventilation (m ³ /h)	Noise dB(A)
SCR-7,5/10PM2	7.5	5 - 10	480 - 950	128	1/2"	1 260	67±3
SCR-11/10PM2	11	5 - 10	750 - 1 500	128	3/4"	2 000	69±3
SCR-15/10PM2	15	5 - 10	1 000 - 2 000	128	3/4"	2 000	71±3

FAD performance is measured in accordance with the current version of ISO 1217, Annex C and is given at an outlet pressure of 10 bar. The noise level is indicated at a distance of 1 m from the machine.

Minimum dimensions

Thanks to the reduction of the size of the drive train, the revolutionary positioning of the oil reservoir, the integration of the electrical switchboard into the frequency converter and the arrangement of the individual components, the size of the machine with the pressure vessel could be reduced to an incredible minimum. The SCR-PM2 compressors thus occupy less than 0.75m² of installation space!



Order No.	Length (mm)	Width (mm)	Height (mm)	Weight (kg)
SCR-7,5/10PM2	1 208	550	1 040	280
SCR-11/10PM2	1 218	605	1 130	320
SCR-15/10PM2	1 218	605	1 130	340

Extended 5-year warranty

We are confident in the quality of the technical design of the SCR-PM2 series compressors, the components used and our quality system of production. We therefore offer all customers the option of extending the standard warranty period to 5 years as a surcharge for the machine. Our extended warranty concept is not limited by the number of operating hours, does not require signing service contracts or shortening preventive maintenance intervals.





Authorized distributor of SCR brand for the
Czech and Slovak Republics:

VSK Profi, s.r.o.
Hřbitovní 1324/27a
312 00 Plzeň - Doubravka

Phone +420 377 152 211
E-mail info@vskprofi.cz
Website www.scr-kompresory.cz

Your expert dealer: